

DRENDO
BOX
PUMPING STATION

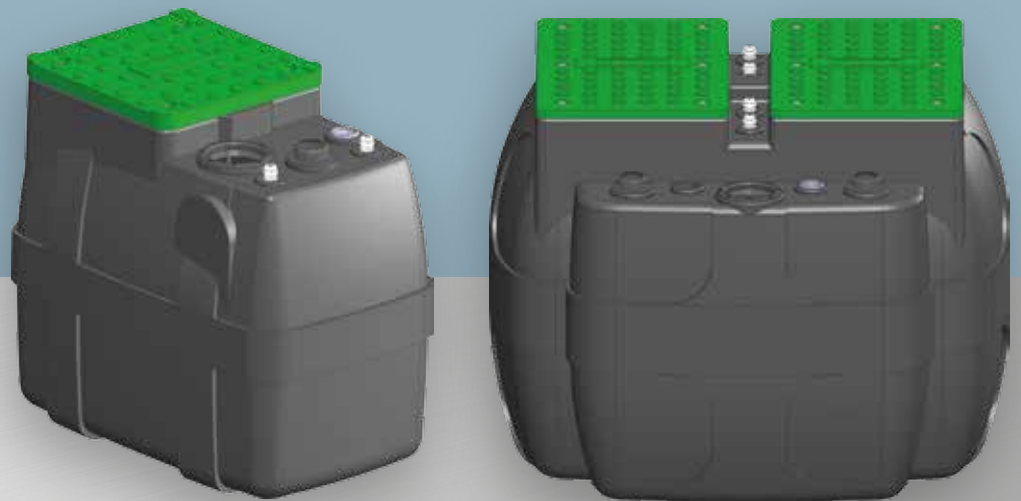

Stazioni di sollevamento

PE pumping stations



Applicazioni

Le stazioni di sollevamento Dreno Box, trovano il loro impiego nella raccolta e il rilancio di acque chiare domestiche, nei casi dove i collettori fognari si trovino ad un livello superiore quindi non confluibili per gravità.

Liquidi Compatibili

Acque piovane, acque chiare e sporche provenienti dalle utenze domestiche.

Installazione

L'installazione è semplice e veloce, i serbatoi vengono forniti con presacavi per cavi di alimentazione ed eventuali galleggianti. In tutte le connessioni rapide è presente una guarnizione che ne garantisce la tenuta.

Dreno Box 200

Serbatoio in polietilene	
Capacità	200 L
Dimensioni	785x490 H710
Temperatura	+40°C

Dreno Box 600

Serbatoio in polietilene	
Capacità	600 L
Dimensioni	925x1135 H870
Temperatura	+40°C

Applications

The Dreno Box pumping station finds its ideal use in those applications where the main sewer line is located at a higher level.

Liquids

Rain water, grey water and sewage of domestic origin.

Installation

Dreno Box installation is fast and easy. The product is supplied with or without coupling foot and float switch system for single or duplex installation both in single-phase and three-phase.

Dreno Box 200

Tank in PE	
Capacity	200 L
Dimensions	785x490 H710
Temperature	+40°C

Dreno Box 600

Tank in PE	
Capacity	600 L
Dimensions	925x1135 H870
Temperature	+40°C

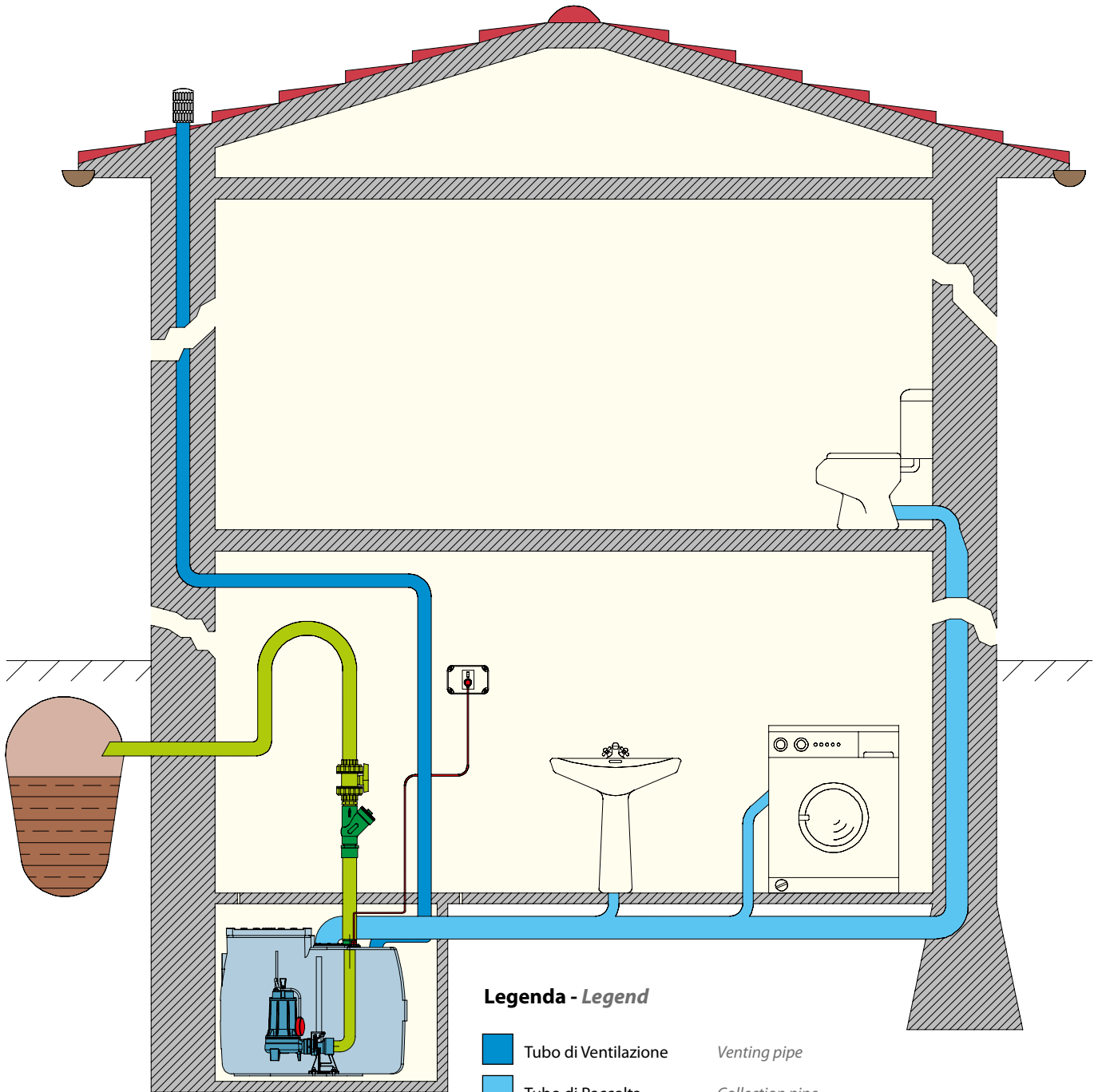

Dreno Box

Legenda - Legend

- | | | |
|---|-------------------------|-------------------------|
|  | Tubo di Ventilazione | <i>Venting pipe</i> |
|  | Tubo di Raccolta | <i>Collection pipe</i> |
|  | Tubo di Mandata | <i>Delivery pipe</i> |
|  | Valvola di non ritorno | <i>Non return valve</i> |
|  | Rete Fognaria | <i>Sewer line</i> |
|  | Alimentazione Elettrica | <i>Electricity feed</i> |

DRENO BOX 200

Inlet: Diametro 110 mm
Outlet: Installazione mobile: 1"1/4 - 1"1/2 - 2"
 Installazione fissa: Ø 63 mm
Kg: 12 (senza pompa ed accessori)
Ventilazione: guarnizione 50 mm
Pressacavo: N. 2 M20+tappo chiusura
Pompe installabili: 1

Inlet: Diametro 110 mm
Outlet: Mobile installation: 1"1/4 - 1"1/2 - 2"
 Stationary installation: Ø 63 mm
Kg: 12 (without pump and accessories)
Ventilation: 50 mm seal
Cable clamp: N. 2 M20+closing cup
Pumps installed: 1

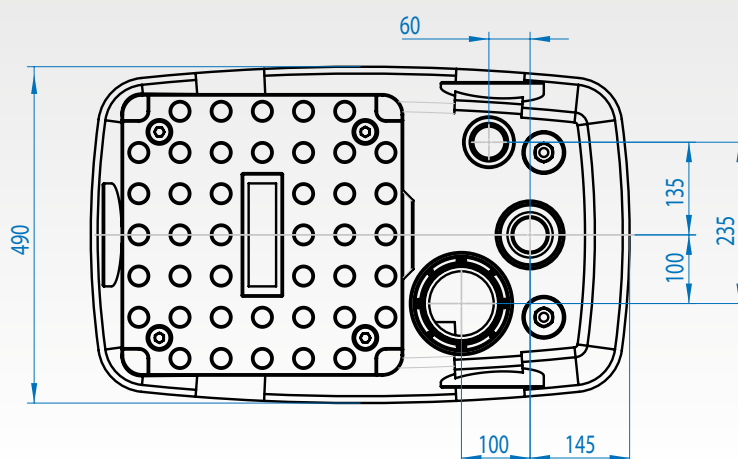
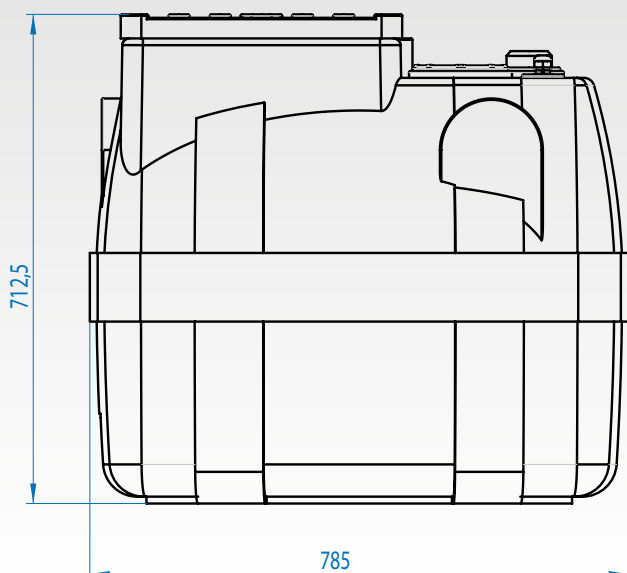

DRENO BOX 600

Inlet: Diametro 110 mm
Outlet: Installazione mobile: 1"1/4 - 1"1/2 - 2"
 Installazione fissa: Ø 63 mm
Kg: 32 (senza pompa ed accessori)
Ventilazione: guarnizione 50 mm
Pressacavo: N. 4 M20+2 tappi chiusura
Pompe installabili: 2

Inlet: Diametro 110 mm
Outlet: Mobile installation: 1"1/4 - 1"1/2 - 2"
 Stationary installation: Ø 63 mm
Kg: 32 (without pump and accessories)
Ventilation: 50 mm seal
Cable clamp: N. 4 M20+2 closing cups
Pumps installed: 2

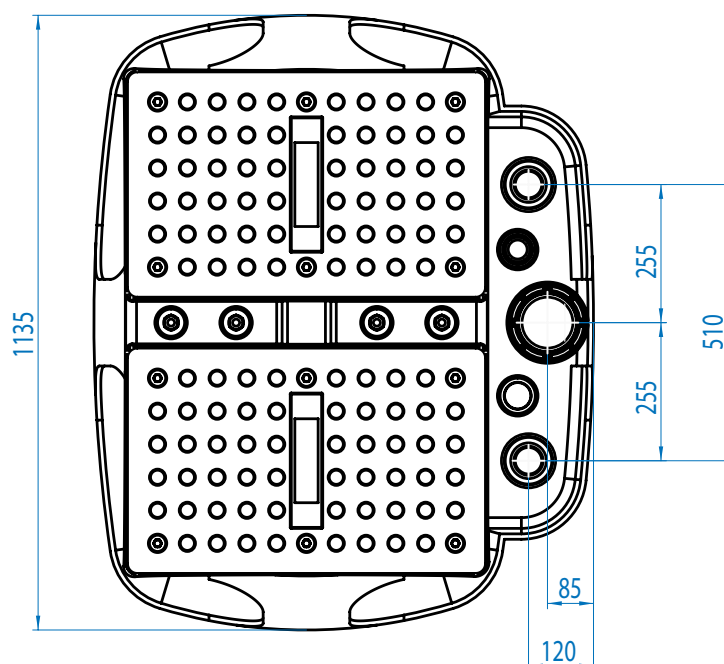
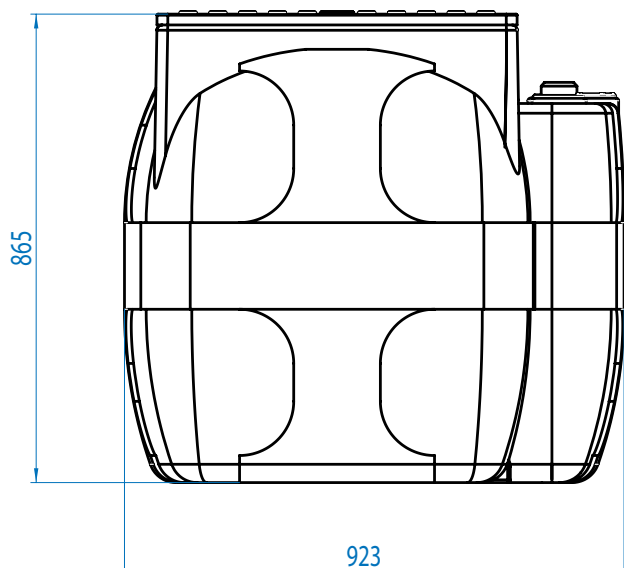

Configurazioni disponibili Available versions

Versione con Girante Vortex - Installazione mobile With Vortex impeller - Mobile installation

Modello Model	V	P2	Outlet	Passaggio libero Free Passage
ALPHA V 2	230/400	0,56	G 1"1/2	35 mm
ALPHA V 3	230/400	0,75	G 1"1/2	35 mm
ALPHA V 22	230/400	0,56	G 2"	40 mm
ALPHA V 32	230/400	0,75	G 2"	40 mm
ALPHA V 4	230/400	1,1	G 2"	45 mm
ALPHA V 55	230/400	1,5	G 2"	45 mm
ALPHA V PRO 50-2/060	230/400	0,6	G 2"	50 mm
ALPHA V PRO 50-2/080	230/400	0,8	G 2"	50 mm
ALPHA V PRO 50-2/110	230/400	1,1	G 2"	50 mm
ALPHA V PRO 50-2/150	230/400	1,5	G 2"	50 mm
ALPHA V PRO 50-2/220	230/400	2,2	G 2"	50 mm

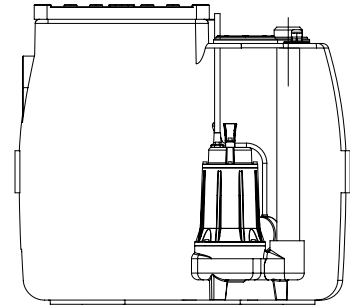

Versione con Girante Vortex - Installazione fissa With Vortex impeller - Stationary installation

Modello Model	V	P2	Outlet	Passaggio libero Free Passage
COMPATTA 2	230/400	0,56	G 1"1/2	35 mm
COMPATTA 3	230/400	0,75	G 1"1/2	35 mm
COMPATTA 22	230/400	0,56	G 2"	40 mm
COMPATTA 32	230/400	0,75	G 2"	40 mm
COMPATTA 4	230/400	1,1	G 2"	45 mm
COMPATTA 55	230/400	1,5	G 2"	45 mm
COMPATTA PRO 50-2/060	230/400	0,6	G 2"	50 mm
COMPATTA PRO 50-2/080	230/400	0,8	G 2"	50 mm
COMPATTA PRO 50-2/110	230/400	1,1	G 2"	50 mm
COMPATTA PRO 50-2/150	230/400	1,5	G 2"	50 mm
COMPATTA PRO 50-2/220	230/400	2,2	G 2"	50 mm
DNA 50-2/110 M/T	230/400	1,1	DN50 - G 2"	50 mm
DNA 50-2/150 M/T	230/400	1,5	DN50 - G 2"	50 mm
DNA 50-2/220 T	230/400	2,2	DN50 - G 2"	50 mm
DNA 50-2/220-1 T	230/400	2,2	DN50 - G 2"	50 mm
DNA 50-4/090 M/T	230/400	0,9	DN50 - G 2"	50 mm

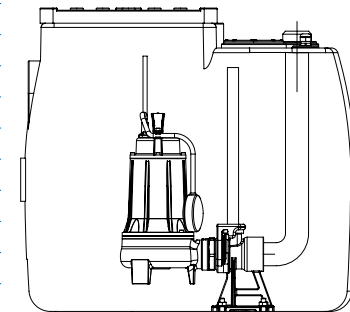

Versione con sistema di triturazione con installazione sia fissa che mobile Stationary and mobile installation with grinder pumps

Modello Model	V	P2	Outlet
Grix 100	230/400	0,9	G 1"1/4
Grix 150	230/400	1,1	G 1"1/4
Grix 200	230/400	1,4	G 1"1/4
GM-GT 32/2/110 C.149	230/400	0,9	G 2"
GM-GT 32/2/110 C.150	230/400	1,1	G 2"

